

**異面工作, 裏面共作, scenario**

**이면공작, 이면공작, 시나리오**

자기자신의 사회적 이름으로

저소득 국가의

경제적 주변부

디자이너의

시간 밀도 높이기 ( 시간의 의미는 용법이다.)

공간 밀도 높이기 ( 공간의 의미는 용법이다.)

이면공작 시나리오는

작업실을 가지고 있는

( 주거 및 생활공간 포함 - 지하, 옥탑, 자취방 )

작가들의

( 작가 1 - 프리랜서 : 사회구저상 앞으로 늘어날 수 밖에 없을 비정규직 노동자)

( 작가 2 - 전업작가 : 여러가지 이유( 정체성 고민 포함)로 인한 구직 단념자, 실업자)

외부와의 소통 문제를

( 살아남기 )

고민하는 프로젝트 입니다

공간 TYPE 2

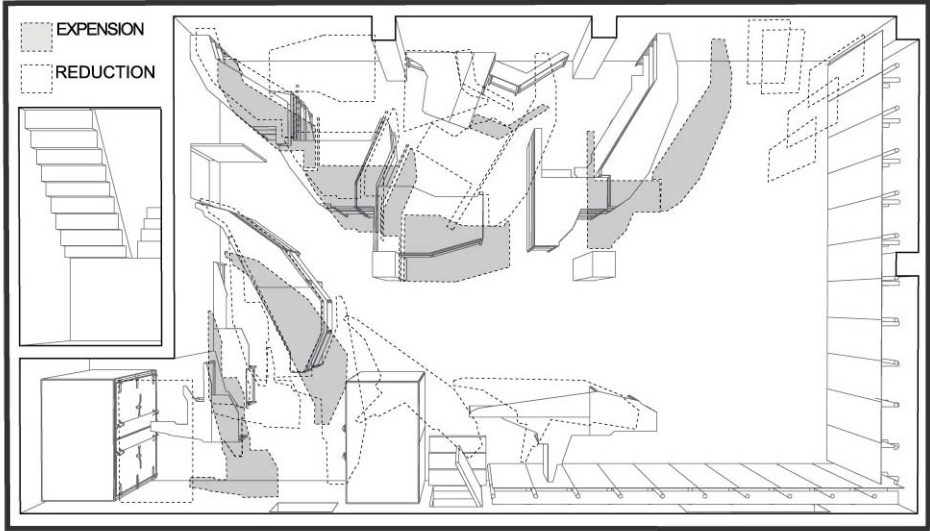
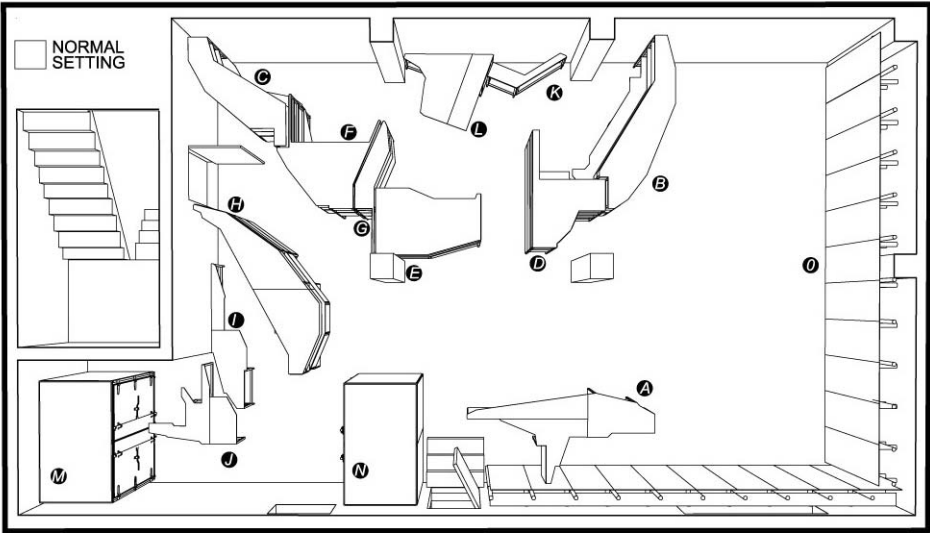

異面工作  
裏面共作  
SCENARIOS

SM- Type ML

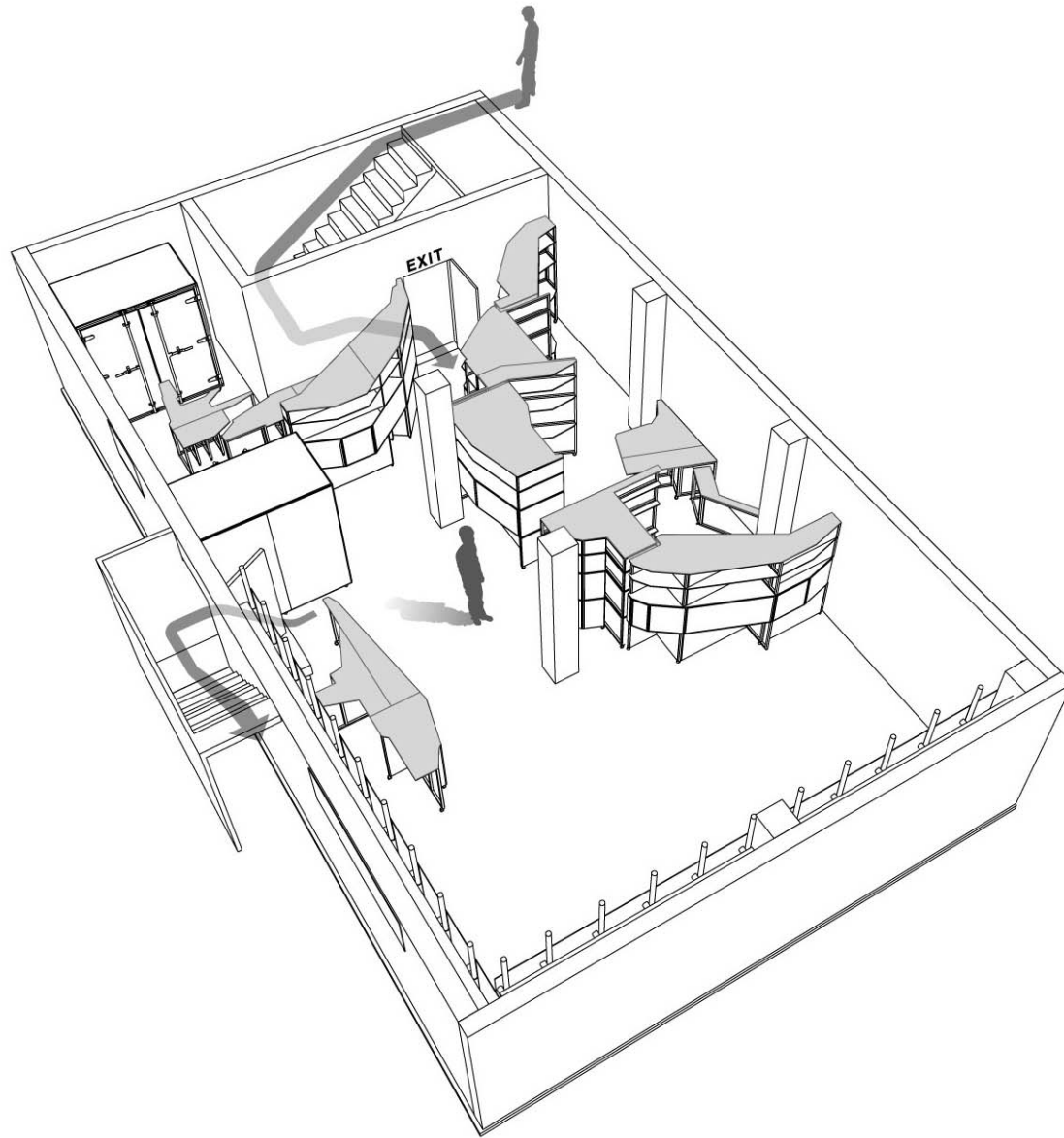



④ **Bar**

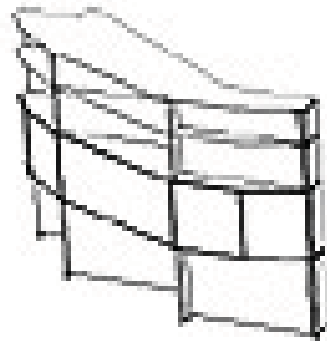

④ **Web designer\* booth\_A**

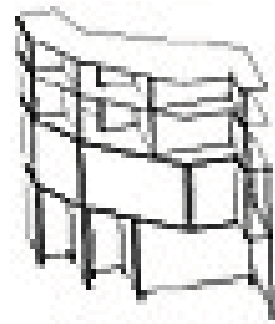

④ **Web designer booth\_B**

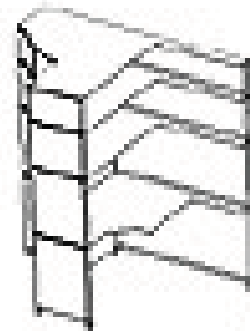

④ **Web designer booth\_C**

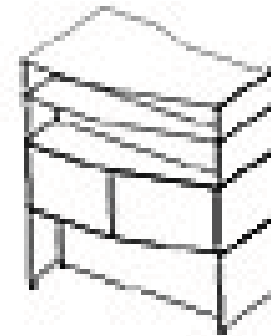

④ **Web designer booth\_D**

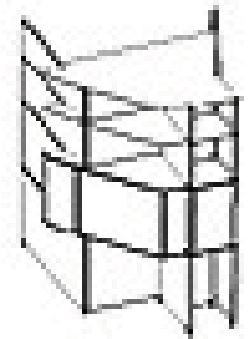

④ **Web designer booth\_E**

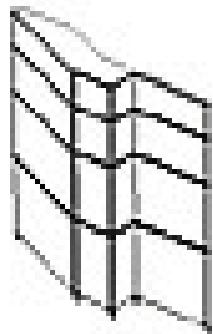

④ **Presentation wall**



④ **Photographer\* booth**

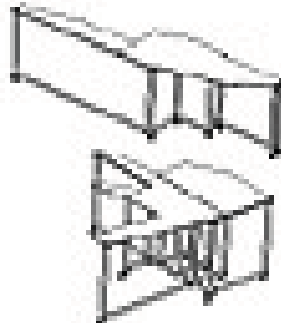

④ ④ **Photograph work table**

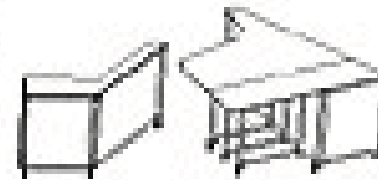

④ ④ **Conference table**

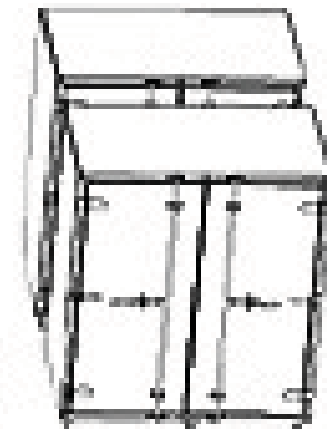

④ ④ **Dark room (B&W / color)**



④ **Storage door**

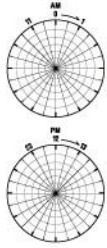

- GALLERY
- SHOP
- CAFE
- EVENT/WORKSHOP
- SHARE DAY
- WORK/LIFE SPACE — CLOSE

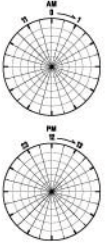
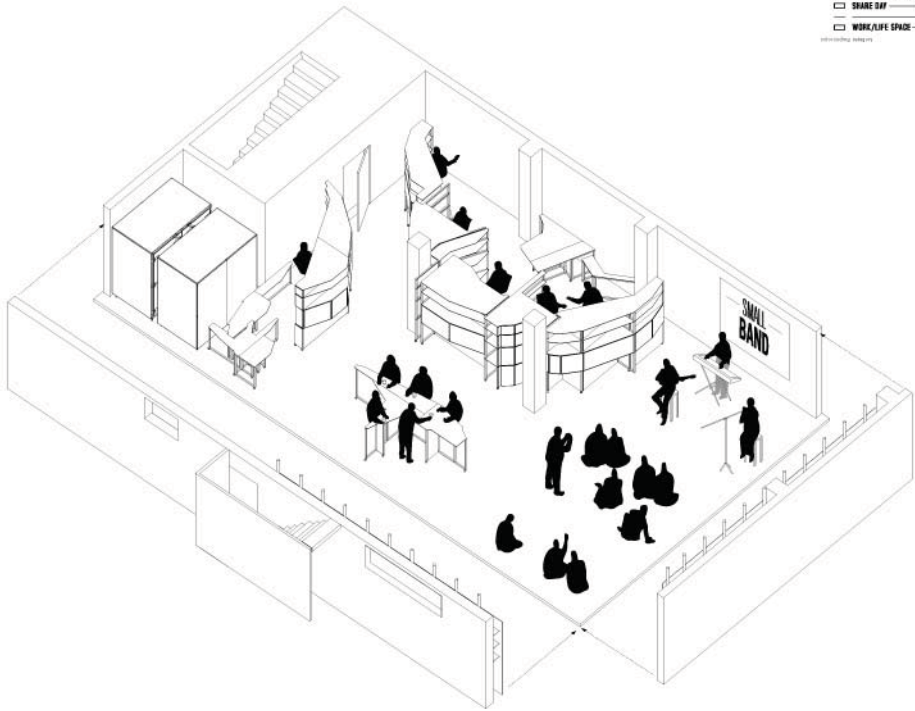

- GALLERY
- SHOP
- CAFE
- EVENT/WORKSHOP
- SHARE DAY
- WORK/LIFE SPACE — CLOSE

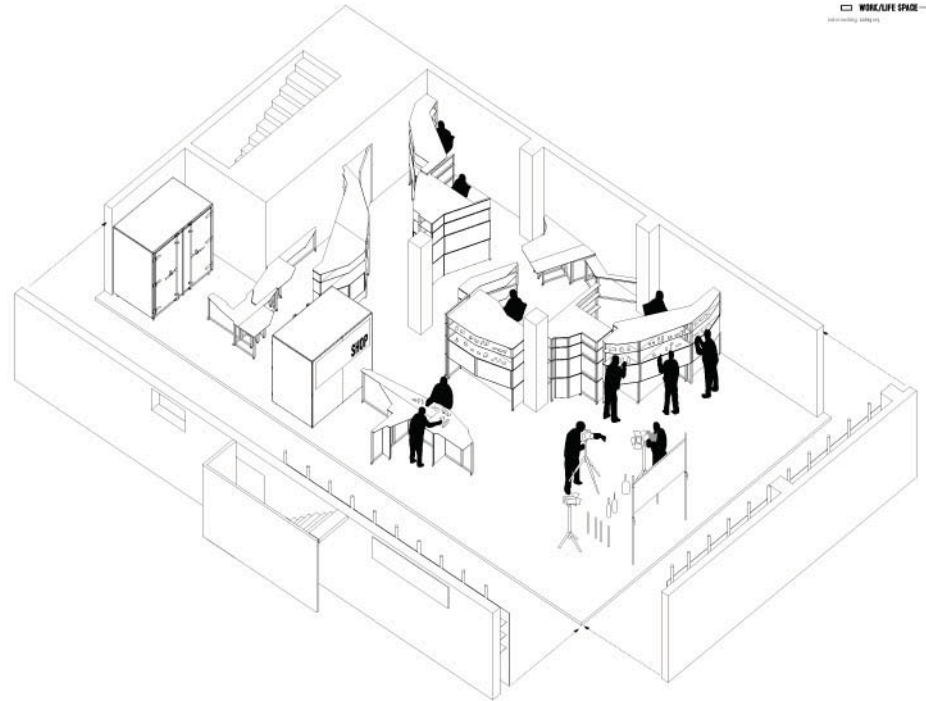



- GALLERY
- SHOP
- CAFE
- EVENT/WORKSHOP
- SHARED OFF
- WORK/LIFE SPACE - CLOSE

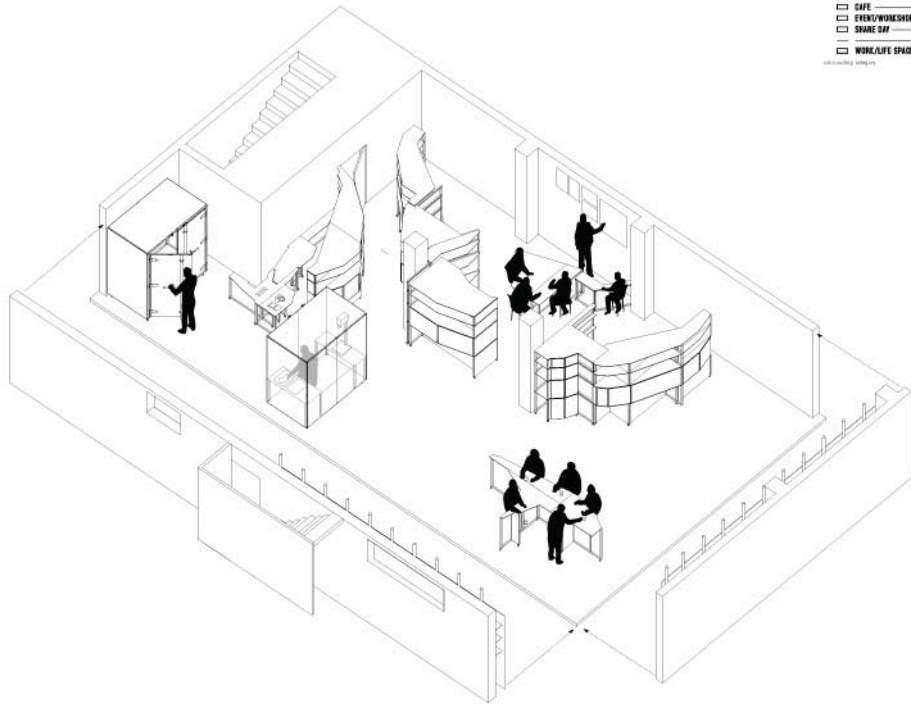

- GALLERY
- SHOP
- CAFE
- EVENT/WORKSHOP
- SHARED OFF
- WORK/LIFE SPACE - CLOSE

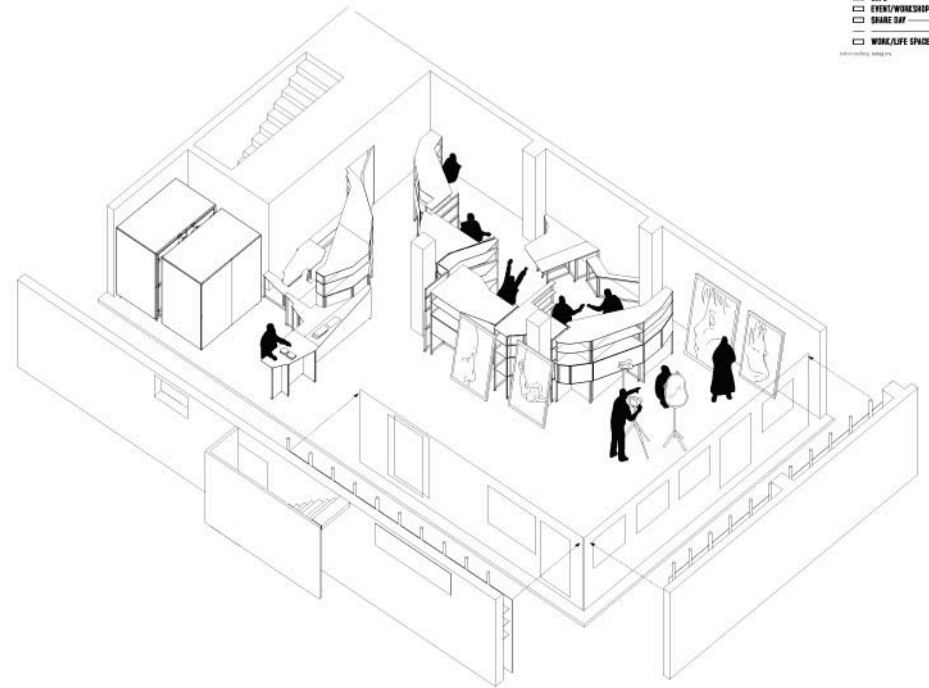



- GALLERY
  - SHOP
  - CAFE
  - EVENT/WORKSHOP
  - SHARE DAY
  - WORK/LIFE SPACE — CLOSE
- © 2010-2011, [unreadable]

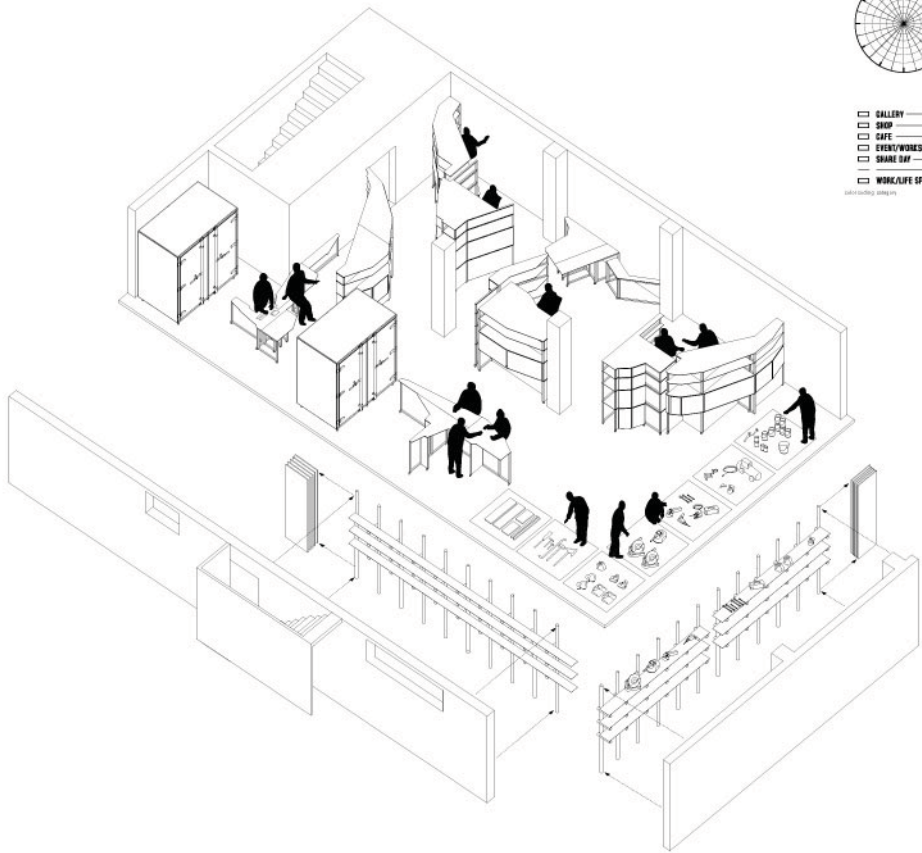















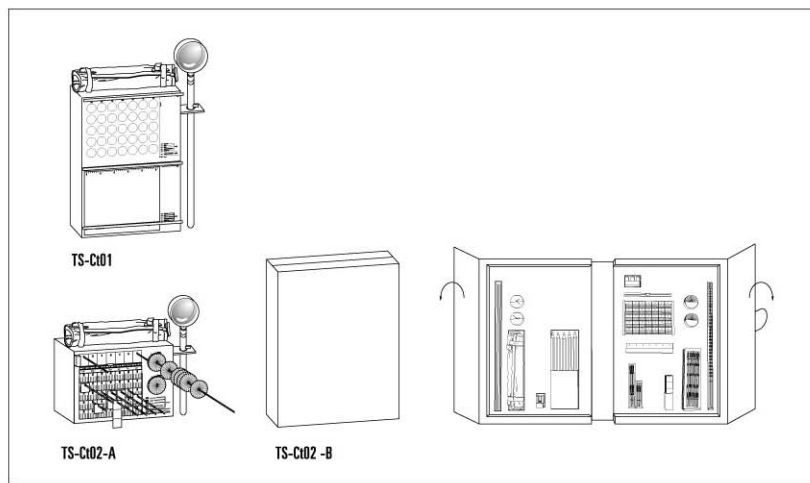
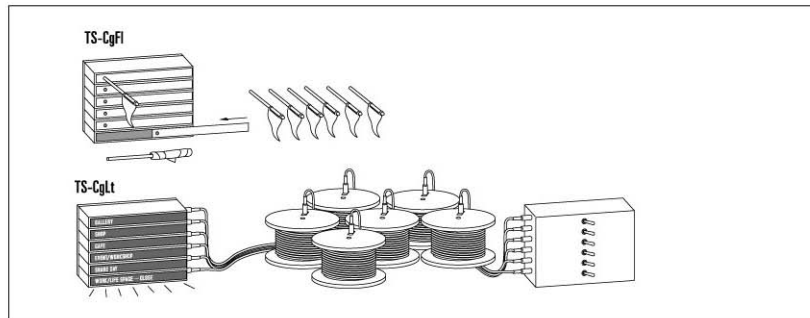
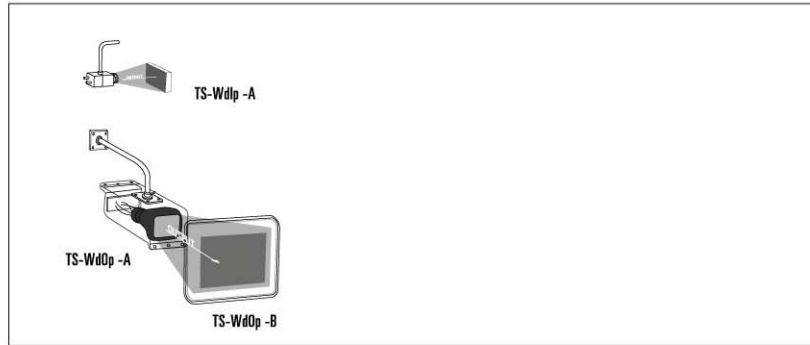
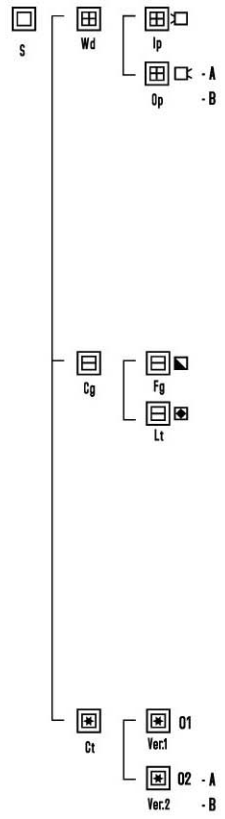

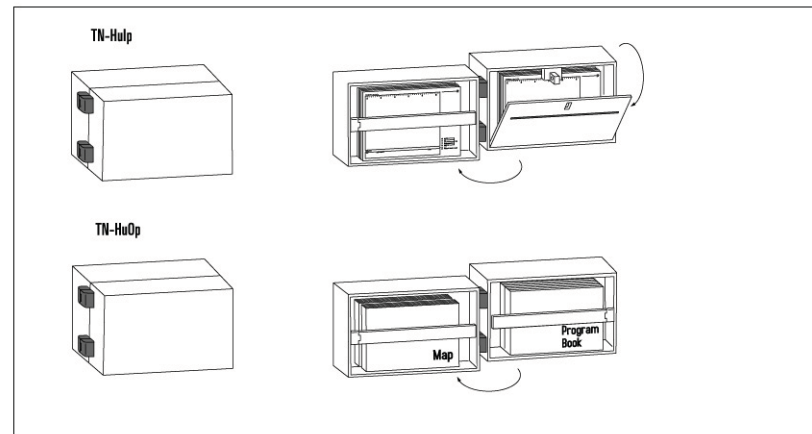
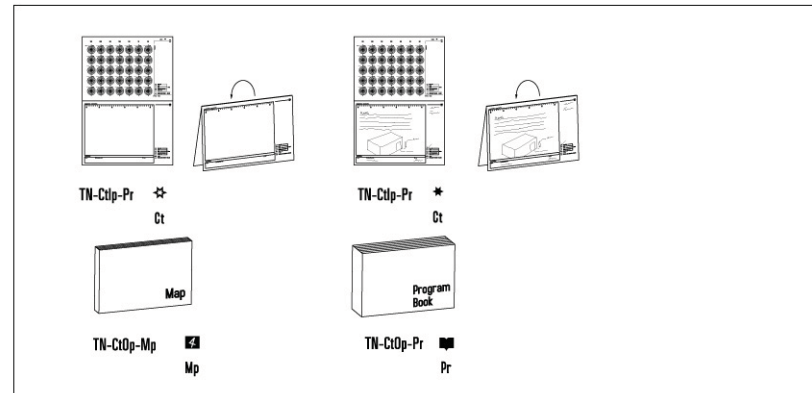
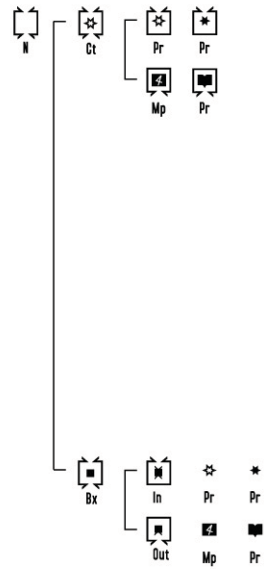





TS-001

	SUN	MON	TUE	WEN	THU	FRI	SAT	
date								month notice
								category
								category
								category
								category
								category
								category
								category
								category
								category
								category
								category
								category
								category
								category
								category
								category
								category
								category
								category
								category
								category
								category
								category
								category
								category
								category
								category
								category
								category
								category
								category
								category
								category
								category
								category
								category
								category
								category
								category
								category
								category
								category
								category
								category
								category
								category
								category
								category
								category
								category
								category
								category
								category
								category
								category
								category
								category
								category
								category
								category
								category
								category
								category
								category
								category
								category
								category
								category
								category
								category
								category
								category
								category
								category
								category
								category
								category
								category
								category
								category
								category
								category
								category
								category
								category
								category
								category
								category
								category
								category
								category
								category
								category
								category
								category
								category
								category
								category
								category
								category
								category

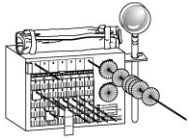

TS-C02-A

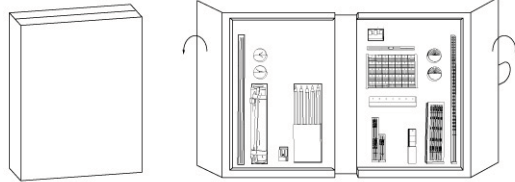

TS-C02-B

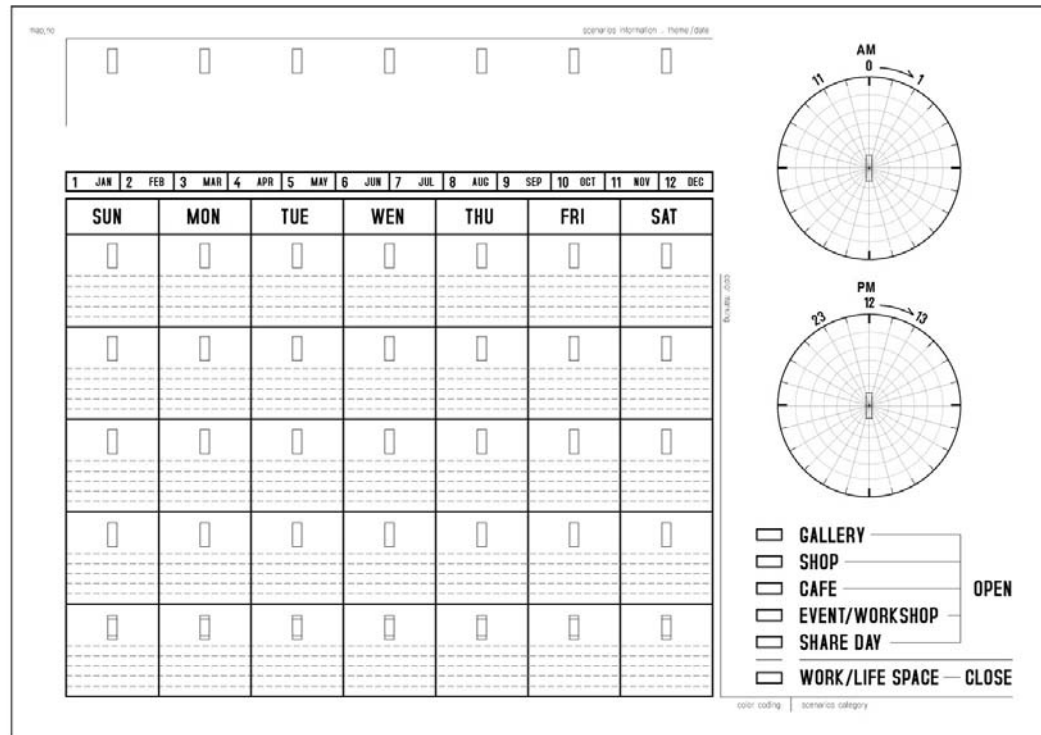

color U.01-01 author (scenarios)

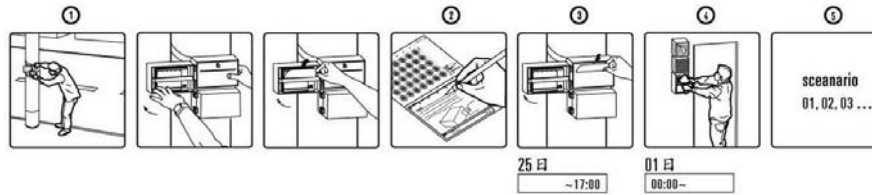

color U.02-02 administrator

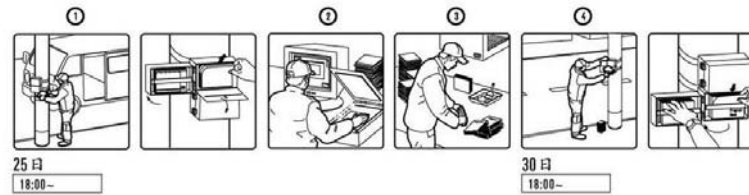

color U.03-03 visitor



MONTHLY 13 14 15 16 17 18 19 20 21 22 23 24 25 26 27 28 29 30 31 01 02 03 04 05 06 07 08 09 10 11 12 13 14

 author (scenarios)  
color U.01-01

 administrator  
color U.02-02

 visitor  
color U.03-03

